

Chris

1/9



12.10.2015

GROUNDPLAN - GRUNDPLAN - PLAN DE MASSE

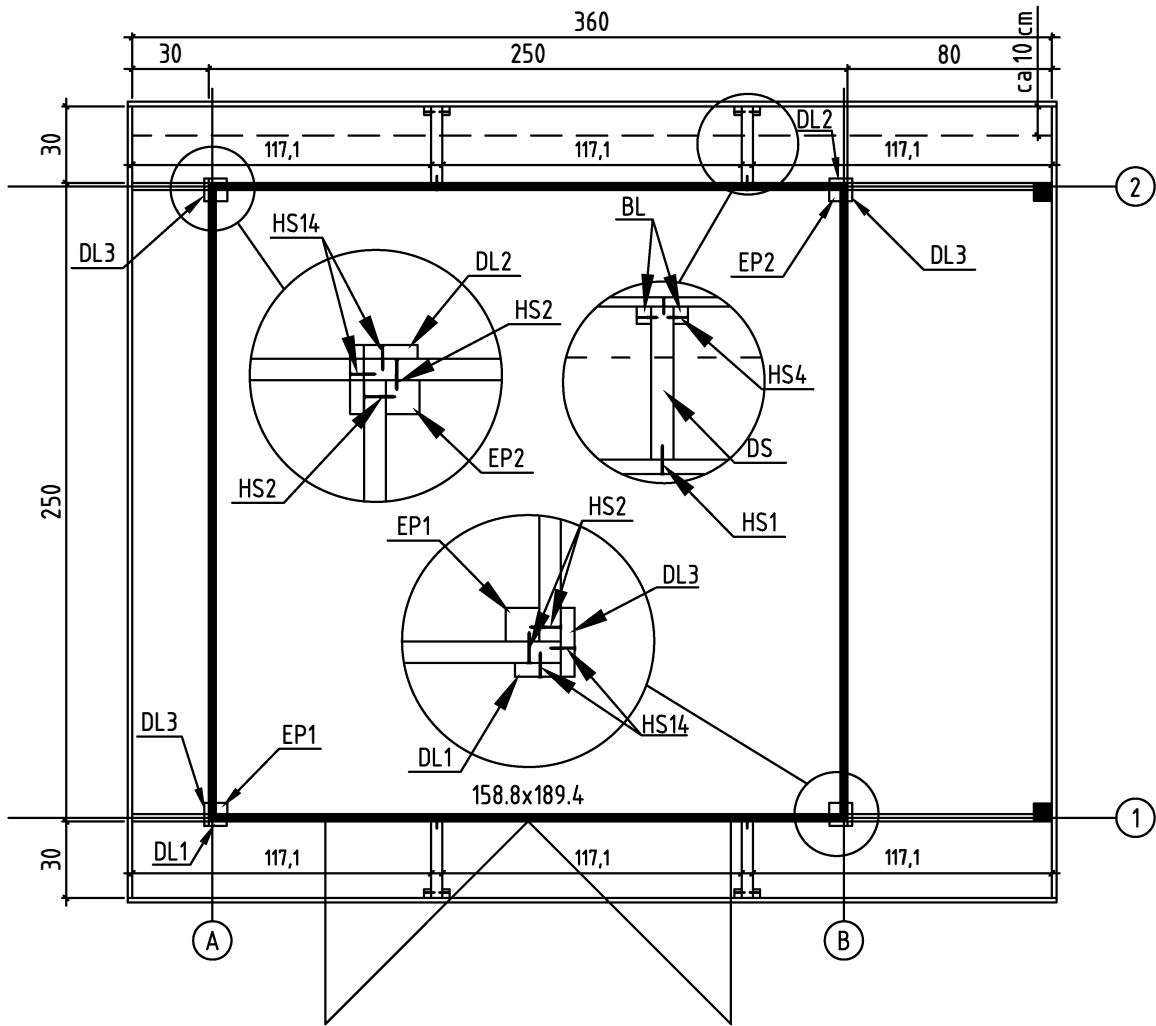

FOUNDATION - FUNDAMENT - FONDATION

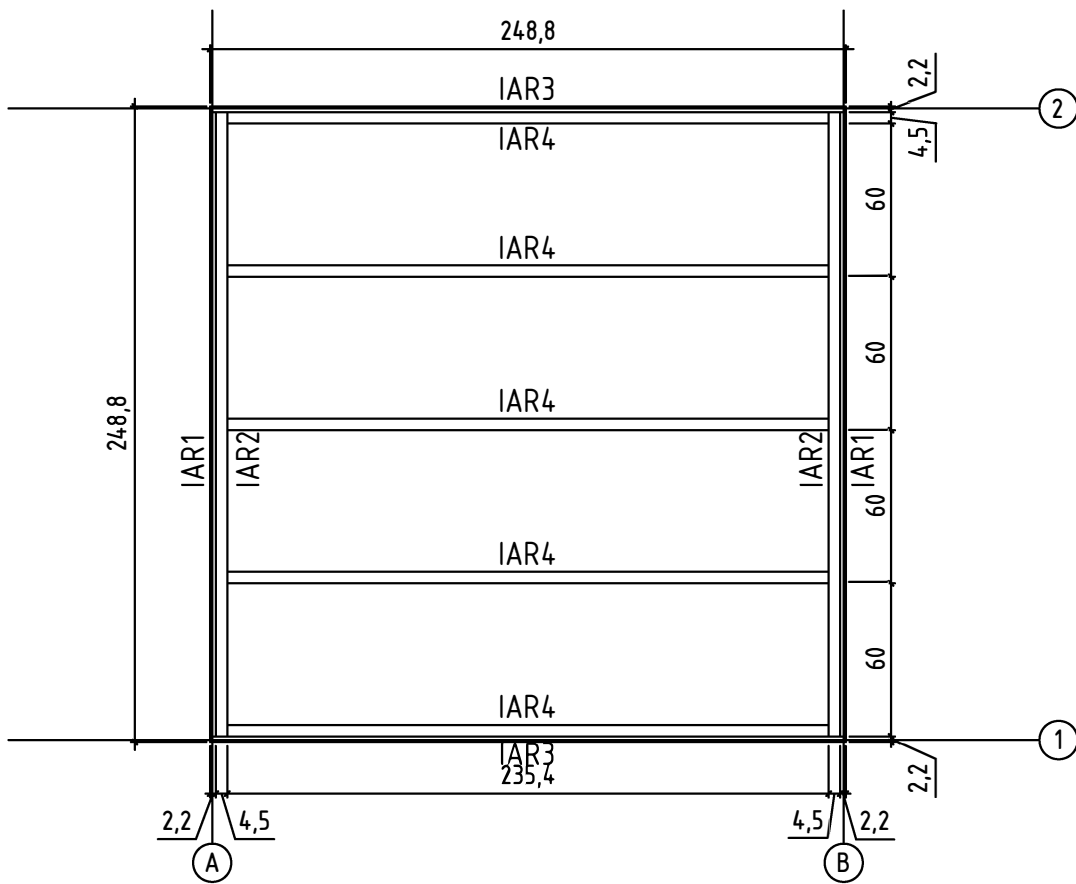

FLOOR BOARDS - FUSSBODENBRETTER - PLAN POSE PLANCHER

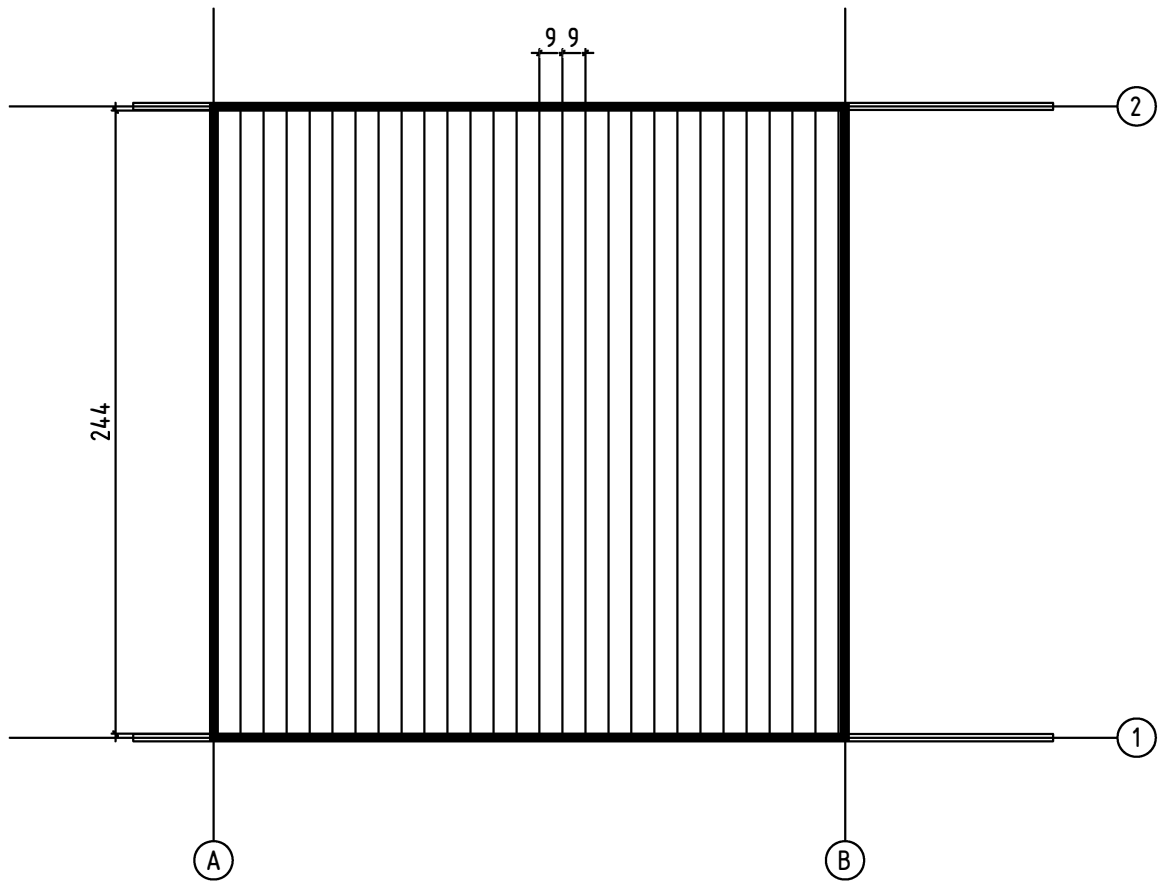



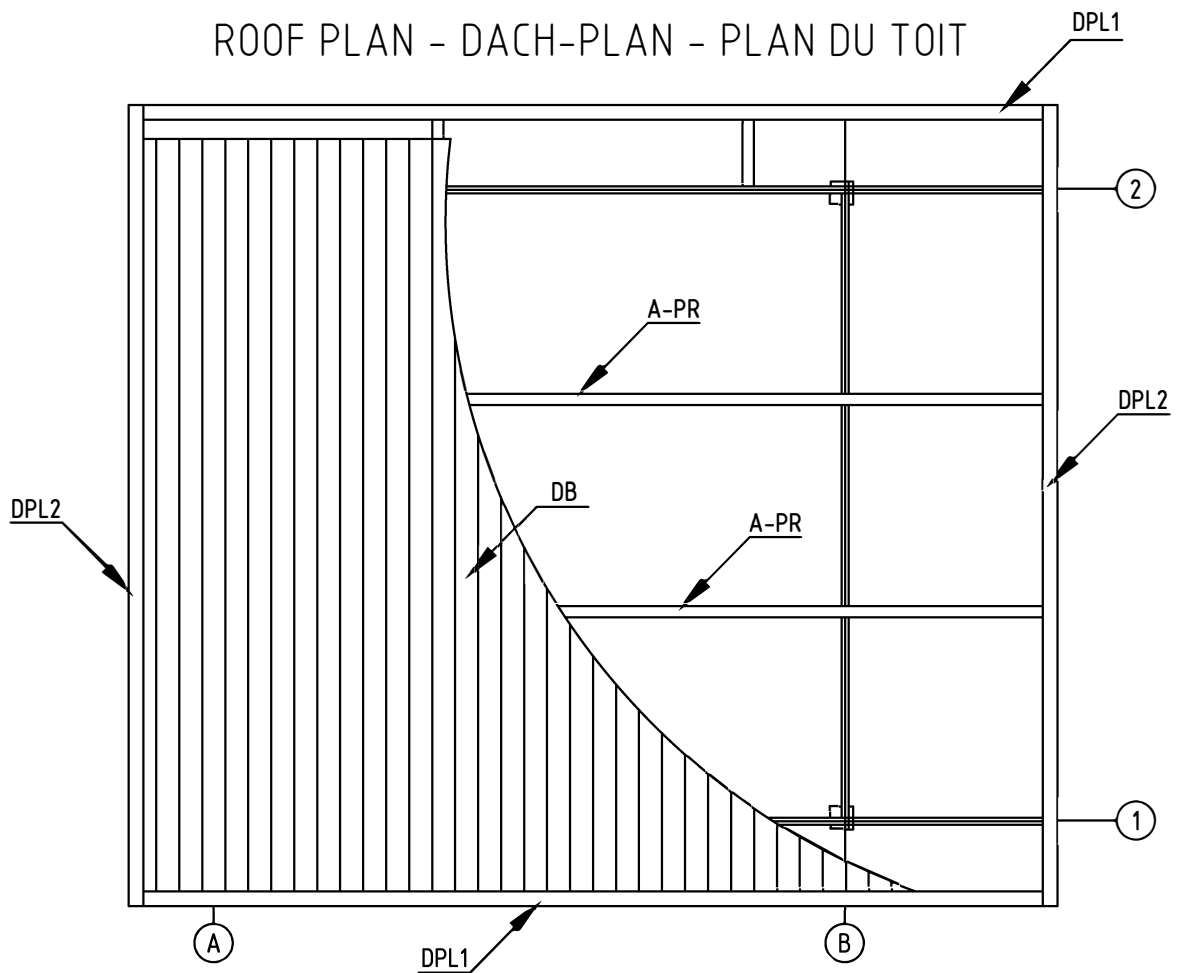

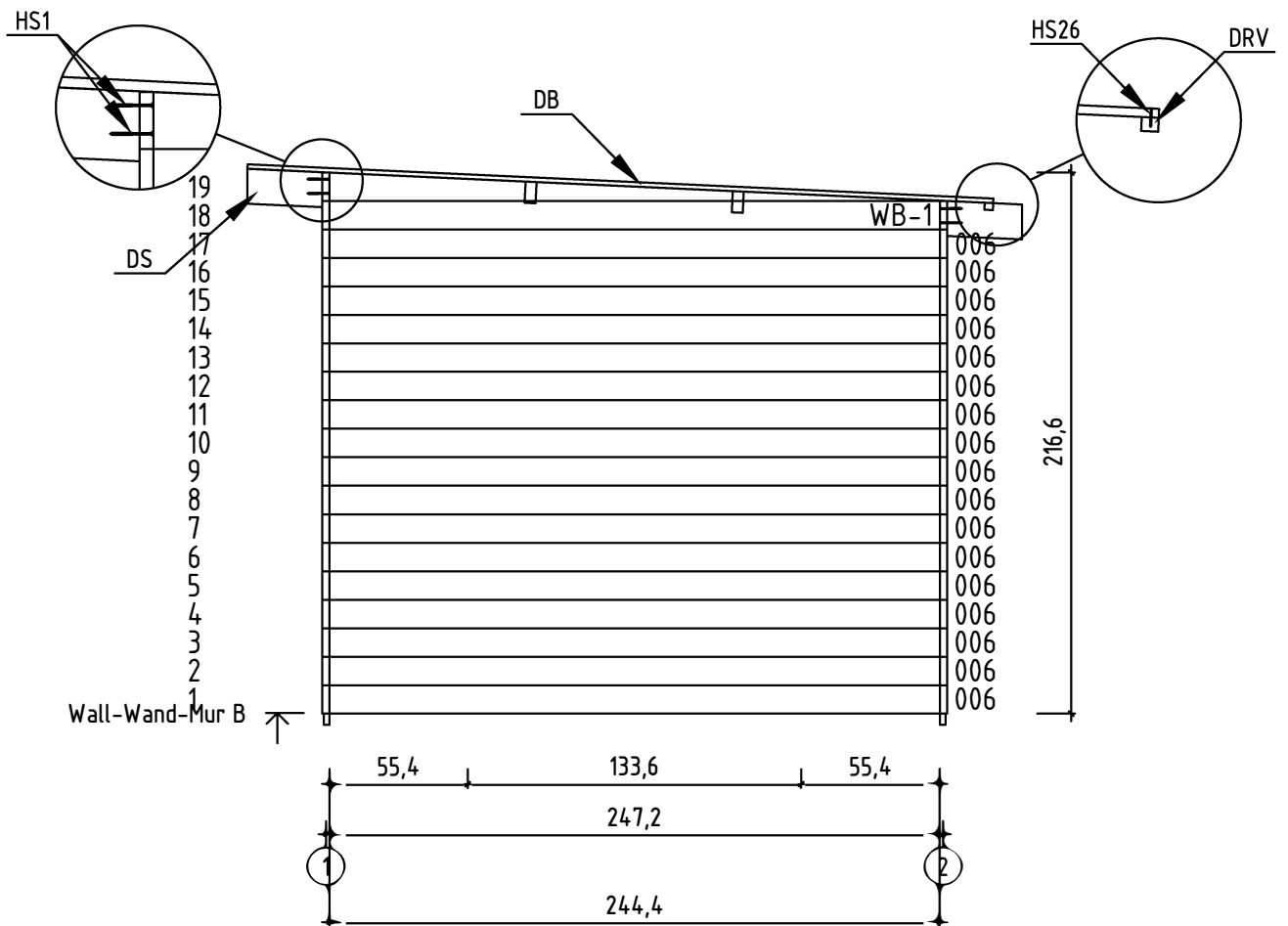
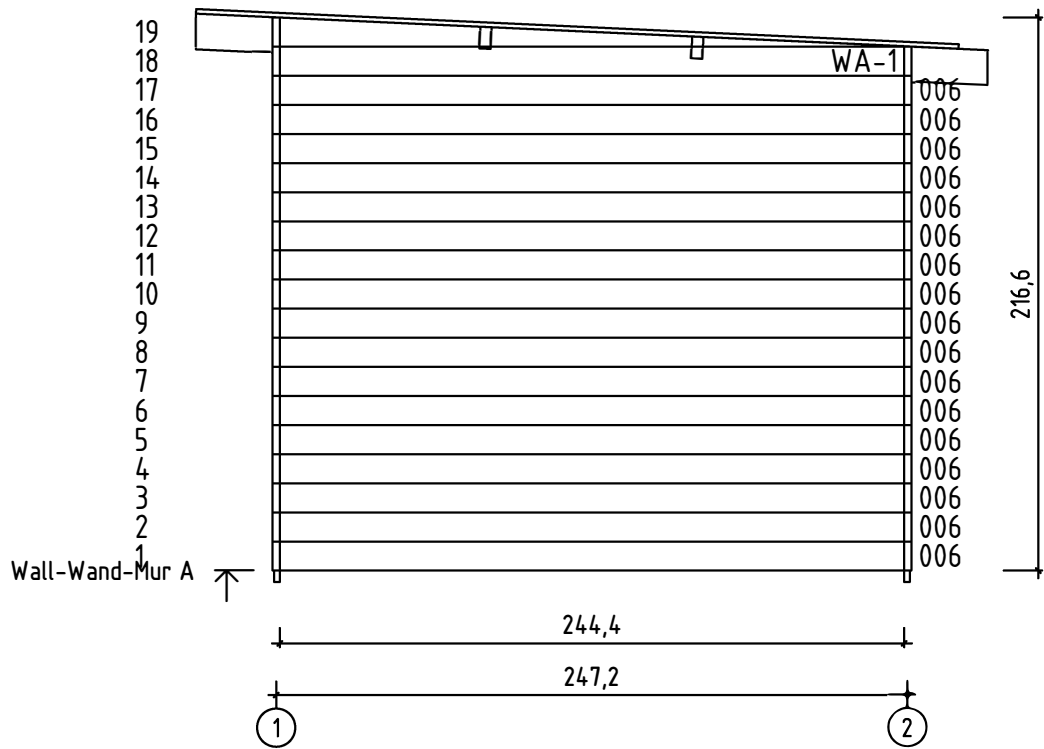

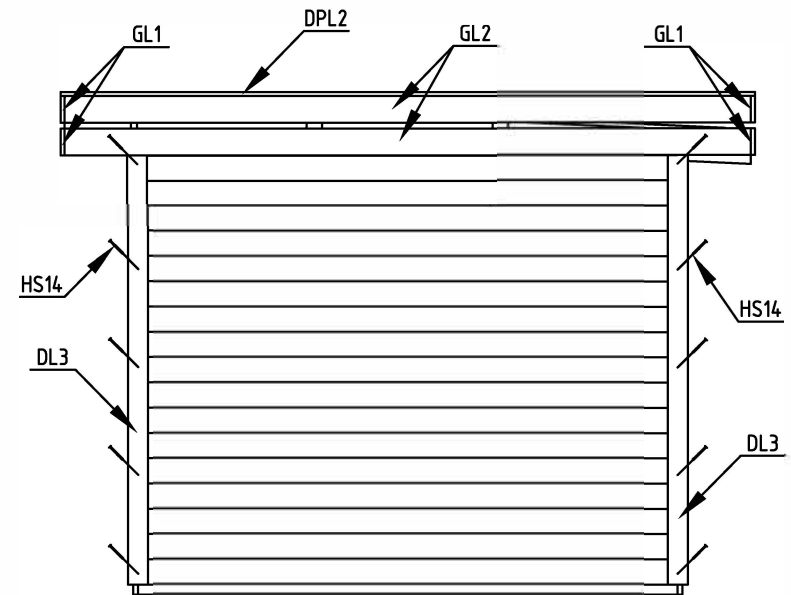
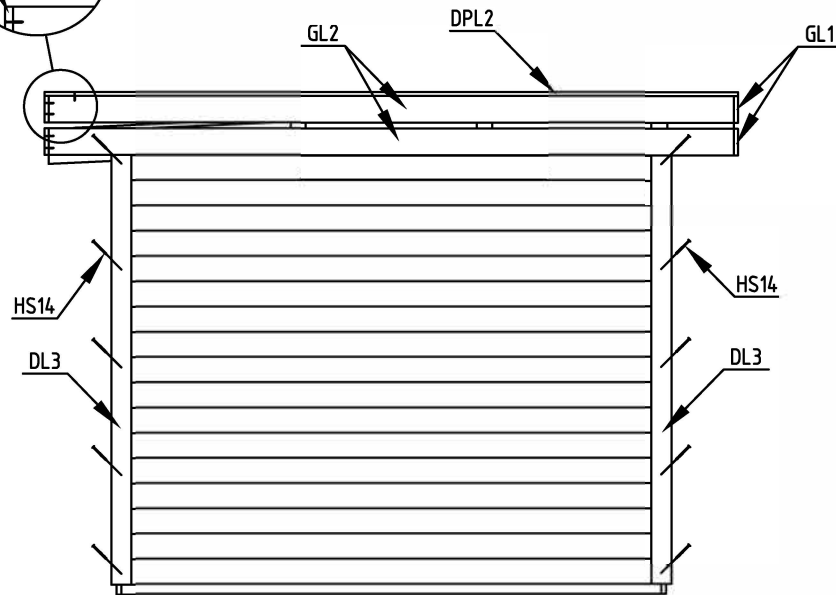
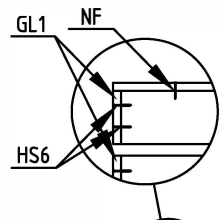
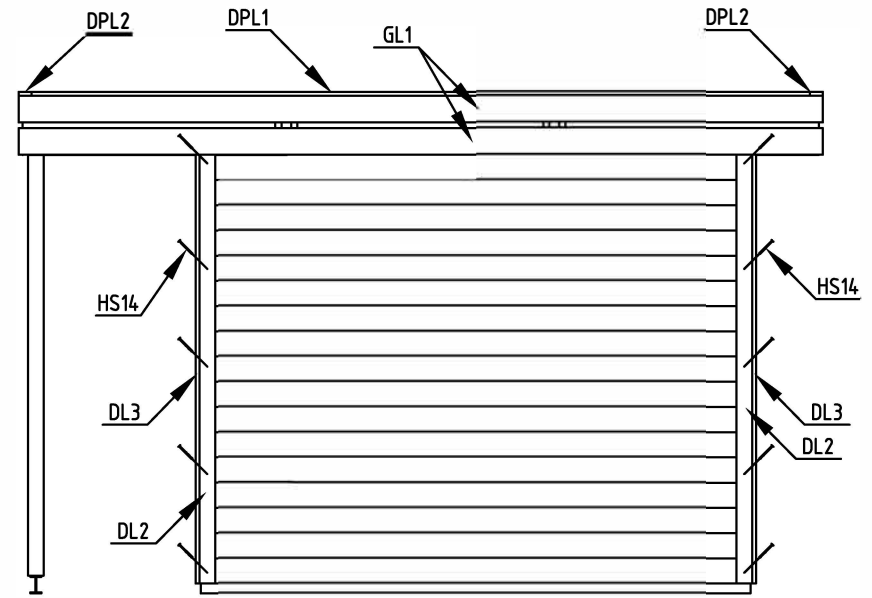
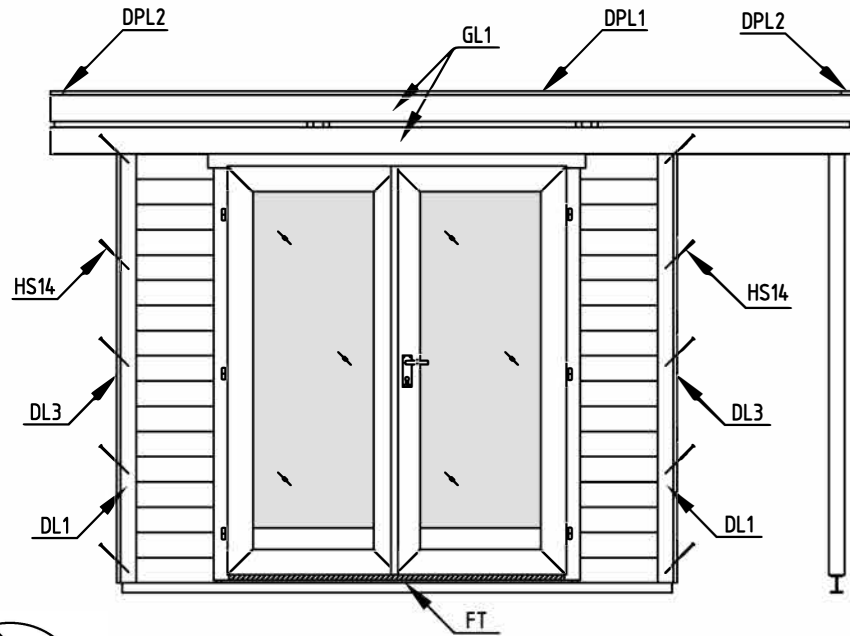

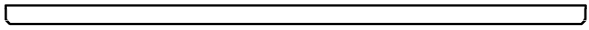
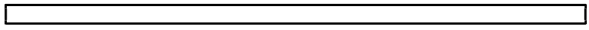
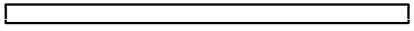
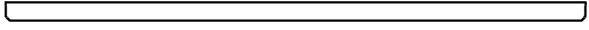
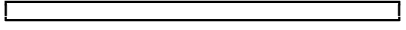
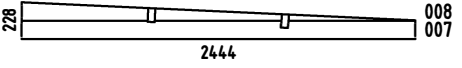
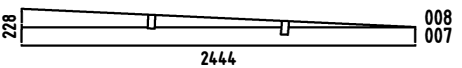
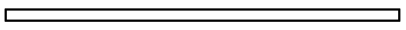
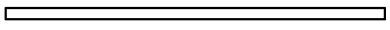
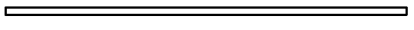
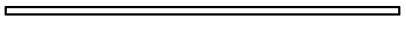
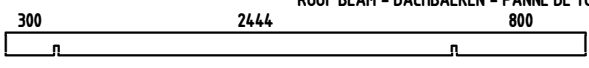



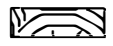
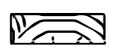

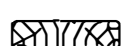
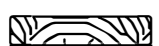
ROOF PLAN - DACH-PLAN - PLAN DU TOIT

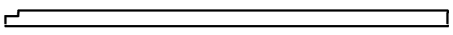







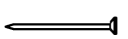

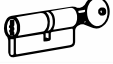
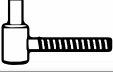

Pos	12.10.2015	Piecelist - Stücklist - Liste des composants	7/9	Q.	P (mm)	L (mm)
001				34	28x114	433
002				1	28x114	3600
003				1	28x114	3600
004				17	28x114	2500
005				1	28x114	3600
006				34	28x114	2444
WA-1				1		
WB-1				1		
IAR2		FOUNDATION - FUNDAMENT - FONDATION		2	45x70	2444
IAR4		FOUNDATION - FUNDAMENT - FONDATION		5	45x70	2354
IAR3		FOUNDATION - FUNDAMENT - FONDATION		2	22x45	2488
IAR1		FOUNDATION - FUNDAMENT - FONDATION		2	22x45	2444
A-PR		ROOF BEAM - DACHBALKEN - PANNE DE TOIT		2	44x140	3600
FB	FLOOR BOARDS - FUSSBODENBRETTER - LAME DE PLANCHER			28	90x18	2440
DB	ROOF BOARDS - DACHBRETTER - VOLIGES			40	90x18	2988
	FLOOR FILLET - FUSSBODENLEISTE - CORNIERE DE FINITION DU PLANCHER				18x18	9.76
DPL2	ROOFING FELT FILLET - DACHPAPPENLEISTE - BAGUETTE DE FIXATION DU FEUTRE BITUMEUX			2	18x58	3136
DPL1	ROOFING FELT FILLET - DACHPAPPENLEISTE - BAGUETTE DE FIXATION DU FEUTRE BITUMEUX			2	18x58	3520
FT	FILLET - LEISTE - LATTES			1	12x22	1588
DL2	CORNER BATTEN - DECKLEISTE - PROFILS DE FINITION ANGLES A L'EXTERIEUR			2	18x70	2052
DL1	CORNER BATTEN - DECKLEISTE - PROFILS DE FINITION ANGLES A L'EXTERIEUR			2	18x70	2166
DL3	CORNER BATTEN - DECKLEISTE - PROFILS DE FINITION ANGLES A L'EXTERIEUR			4	18x90	1938
EP2	CORNER STUD - ECKPFOSTEN - POTEAUX D'ANGLE POUR FIXATION DES MADRIERS			2	44x44	1970
EP1	CORNER STUD - ECKPFOSTEN - POTEAUX D'ANGLE POUR FIXATION DES MADRIERS			2	44x44	2085
P	POST - PFOSTEN - POTEAU			2	70x70	1960

Pos	12.10.2015	Piecelist - Stücklist - Liste des composants	8/9	Q.	P (mm)	L (mm)
DRV	ROOF EDGE REINFORCEMENT - DACHRANDVERSTÄRKUNG - CORNIERE DE RENFORT DE BORD DE TOIT			3	28x34	1170
TL1	FINISHING STRIP FOR DOOR - ABSCHUSSLEISTE FÜR TÜR - MONTANT DE FINITION DES OUVERTURES PORTES			2	18x28	1910
BL	FIXING SLAT FOR DISTANCE SPACERS - BEFESTIGUNGSLEISTE - RENFORTS PLANCHES DE RIVES			8	28x34	250
DS	DISTANCE SPACERS FOR GABLE MOULDING - DACHSTÜZEN - SUPPORTS EXTENSION TOITURE			4	44x140	307
GL2	GABLE MOULDING - GIEBELLEISTE - PLANCHE DE RIVE			4	18x120	3100
GL1	GABLE MOULDING - GIEBELLEISTE - PLANCHE DE RIVE			4	18x120	3636
	SCREW FOR POST - SCHRAUBEN FÜR PFOSTEN - VIS DE FIXATION DES POTEAUX			4	4x60	
	SCREW FOR DOOR FILLET - SCHRAUBE ZUR BEFESTIGUNG TÜRLEISTE - VIS POUR FIXATION BAGUETTE D'ARRET DE PORTE			5	3x30	
HS2	SCREW FOR 1. WALL BEAM - SCHRAUBE FÜR 1. BOHLENREIHE - VIS DE FIXATIONS 1ÈRE RANGÉE DE MADRIERS AVEC POUTRELLES DE FONDATIONS			13	4x60	
HS3	SCREW FOR ROOF BEAMS - SCHRAUBEN FÜR DACHBALKEN - VIS POUR FIXATION PANNES DE TOIT			4	5x120	
HS1	SCREW FOR DOOR JAMB - SCHRAUBE FÜR TÜRRAHMEN - VIS DE FIXATION PARTIE HAUTE AVEC MONTANTS DU CADRE DE PORTE			4	5x90	
	SCREW FOR POST HEIGHT ADJUSTMENT - SCHRAUBEN FÜR RÉGULIATIONSSCHRAUBE FÜR PFOSTEN - VIS DE FIXATION DE SUPPORT RÉGLABLE DE POTEAU			16	6x50	
HS14	SCREW FOR CORNER BATTEN - SCHRAUBEN FÜR DECKLEISTEN - VIS DE FIXATION PROFILS DE FINITION ANGLES A L'EXTERIEUR			48	3.5x35	
HS4	SCREW FOR FIXING FILLET OF DOOR - SCHRAUBEN FÜR FIXIRUNGSLEISTE - VIS POUR PROFIL DE FIXATION DES PORTES			34	4x40	
HS4	SCREW FOR DISTANCE SPACER FIXING SLAT - SCHRAUBEN FÜR BEFESTIGUNGS - LEISTE - VIS DE FIXATION RENFORTS PLANCHES DE RIVES			16	4x40	
HS2	SCREW FOR FOUNDATION - SCHRAUBEN ZUR BEFISTIGUNG FUNDAMENT - VIS DE FIXATIONS DES POUTRELLES DE FONDATIONS			14	4x60	
HS2	SCREW FOR WALL DETAILS - SCHRAUBE FÜR WAND DETAILS - VIS POUR MUR DETAILS			296	4x60	
HS1	SCREW FOR FOUNDATION - SCHRAUBEN ZUR BEFISTIGUNG FUNDAMENT - VIS DE FIXATIONS DES POUTRELLES DE FONDATIONS			10	5x90	
HS1	SCREW FOR FIXING GABLE MOULDING DISTANCE SPACERS TO THE WALL - SCHRAUBEN FÜR DACHSTÜZEN - VIS DE SUPPORTS EXTENSION TOITURE			8	5x90	
DS3	ZN NAIL FOR FLOOR FILLET - ZN NÄGEL FÜR FUSSBODENLEISTE - POINTE POUR CORNIERE DE FINITION DU PLANCHER			20	1.4x40	
SH28	HAMMER BLOCK - SCHLAGHOLZ - CALLE DE FRAPPE			1		
	SCREW FOR DOORSTEP - SCHRAUBEN FÜR SWELLE - VIS POUR FIXATION BARRE DE SEUIL			3	4.5x65	
DS1	ZN NAIL FOR ROOF - ZN NÄGEL FÜR DACHBRETTER - POINTE POUR FIXATION VOLIGES DE TOIT			170	2x50	
DS1	ZN NAIL FOR FLOOR - ZN NÄGEL FÜR FUSSBODENBRETTER - CLOUS POUR PLANCHER			145	2x50	
NF	ZN NAIL FOR ROOFING FELT FILLET - ZN NÄGEL FÜR DACHPAPPENLEISTE - POINTE POUR BAGUETTE DE FIXATION FEUTRE BITUMEUX			30	2x40	

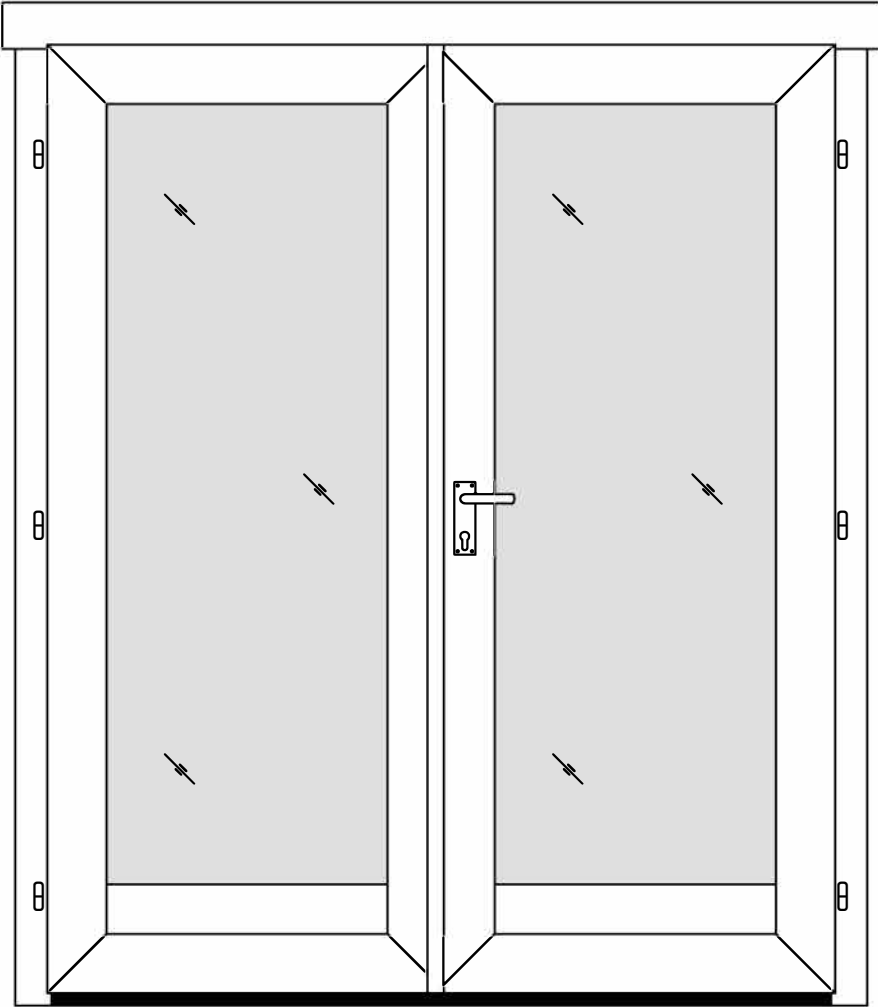
Pos	12.10.2015	Piecelist - Stücklist - Liste des composants	9/9	Q.	P (mm)	L (mm)
HS6	SCREW FOR GABLE MOULDING - SCHRAUBEN FÜR GIEBELLEISTE - VIS DE FIXATION POUR PLANCHE DE RIVE			64	3.5x50	
HS26	SCREW FOR ROOF EDGE REINFORCEMENT - SCHRAUBEN FÜR DACHRANDVERSTÄRKUNG - VIS POUR RENFORT DE BORD DE TOIT			9	4x40	
TL4	DOOR HANDLE FITTINGS - TÜRGRIFF - POIGNEE DE PORTE			1		
TL5	SET OF DOOR LOCK COVERS - SCHLOSSBLENDEN - SET DE GARNITURES DE PORTE			1		
	CYLINDER LOCK - ZYLINDERSCHLOSS - BARILLET DE PORTE			1	30x35	
	MALE BOLT HINGE FOR DOOR - TÜRRIEGEL - PARTIE MALE DE PAUMELLE DE PORTE			6	16x52	
RFP	POST HEIGHT ADJUSTMENT - REGULIERUNGSSCHRAUBE FÜR PFOSTEN - SUPPORT RÉGLABLE DE POTEAU			2	D16	
	DOOR-TÜR-PORTE 1588x1894		TUK.1.100.MVP.MMTb MGC	1		
						

**Allgemeine Montageanleitung - General assembly instructions -
Instructions générales de montage**

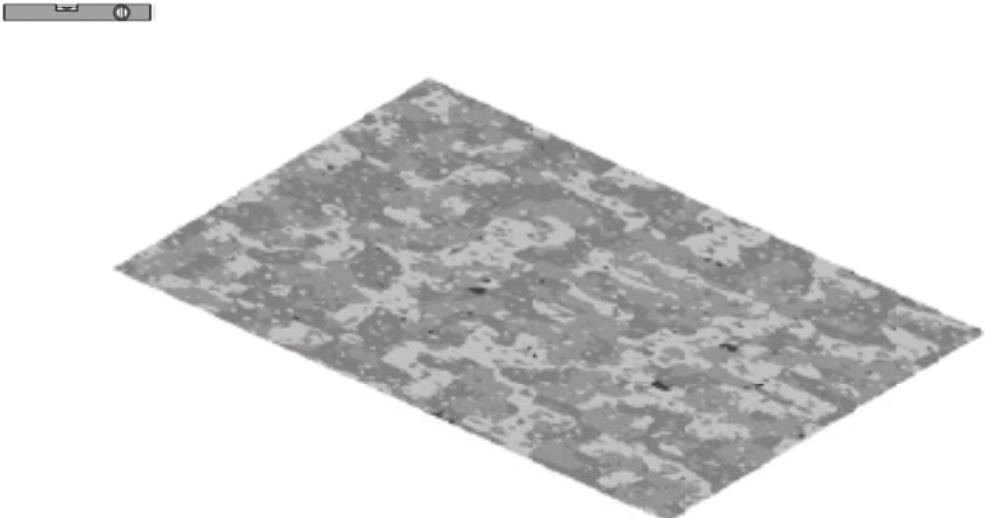
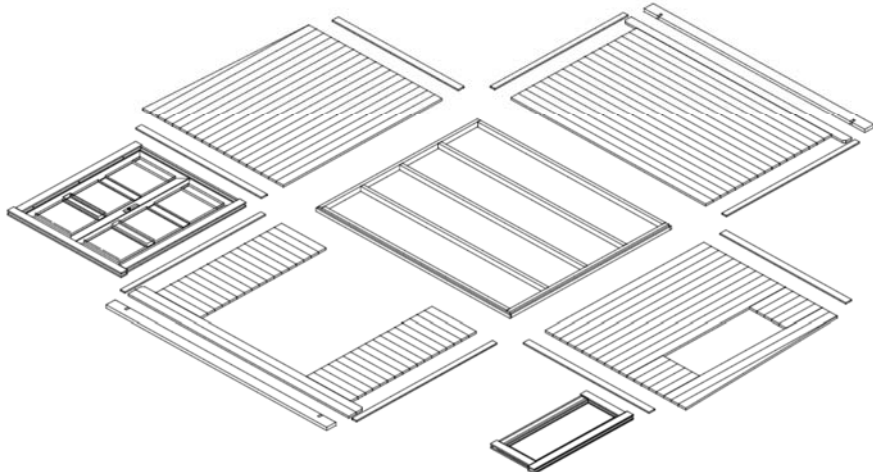
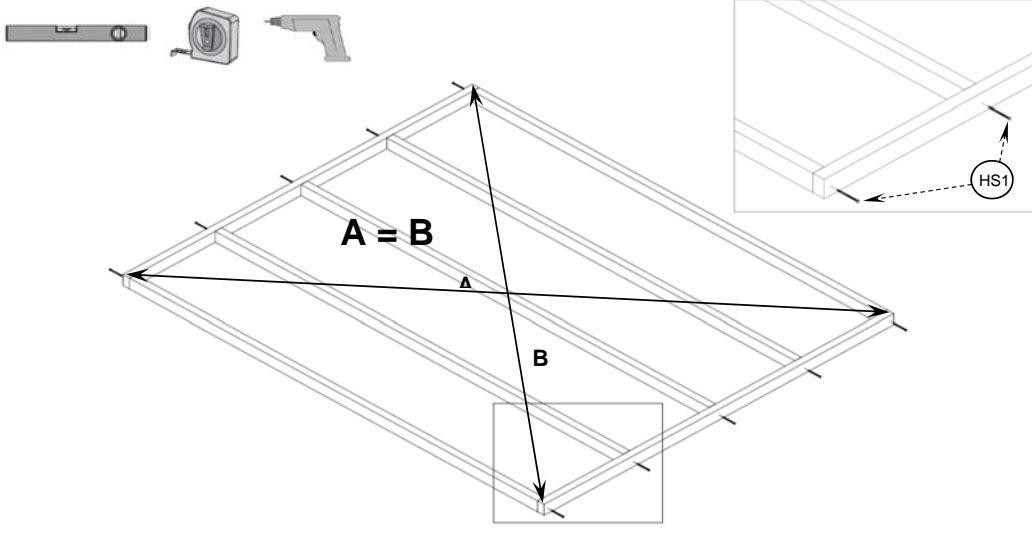
<p>1. Fundament / Foundation / Fondation</p>		
<p>2. Vorbereitung der Einzelteile / Preparation of components / Préparation des composants</p>		
<p>3. Fundamentbalken-Innenrahmen / Base internal frame (foundation joists) / Poutrelles de fondation (extérieur)</p>		<p>Holzschraube / Screw / Vis de fixation 5x90mm (HS1)</p>

<p>4. Fundamentbalken-Aussenrahmen / Base external frame (foundation joists) / Poutrelles de fondation (extérieur)</p>		<p>Holzschraube / Screw / Vis de fixation 4x60 (HS2)</p>
<p>5. 1. bohlenreihe / 1. layer of wall / 1er rang de madriers</p>		<p>Holzschraube / Screw / Vis de fixation 4x60 (HS2)</p>
<p>6. Fussboden / Floor / Plancher</p>		<p>Drahtstift / Nail / Pointes 2x50 (DS1)</p>

<p>7. Eckpfosten / Corner studs / Montants angles et ouverture</p>		<p>Holzschraube / Screw / Vis de fixation 4x60 (HS2)</p>
<p>8. Wandmontage / Wall / Assemblage des mur</p>		<p>Holzschraube / Screw / Vis de fixation 4x60 (HS2)</p>
<p>9. Tür und Fenster / Door and window / Mise en place des ouvertures</p>		

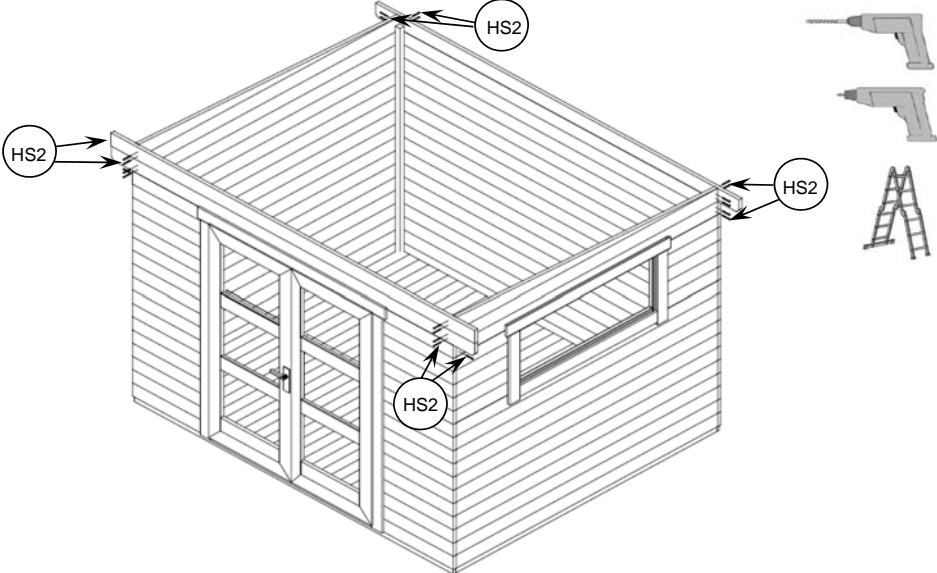
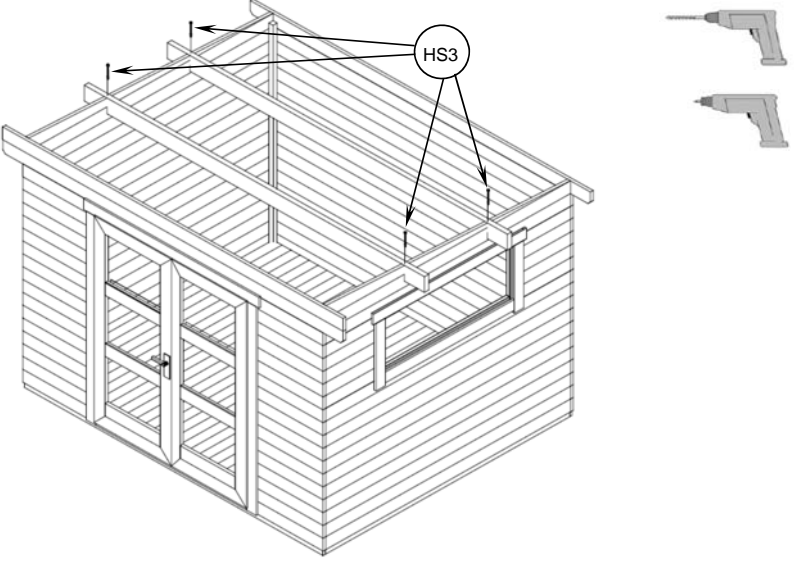
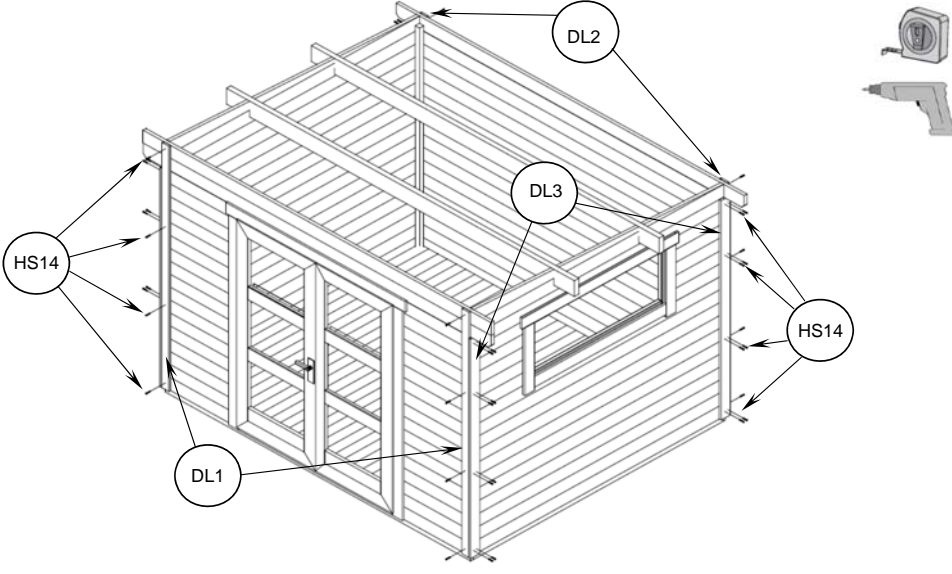
<p>10. Wand- und Giebelmontage / Wall and apex / Mise en place des pignons de toit</p>		<p>Holzschraube / Screw / Vis de fixation 4x60 (HS2)</p>
<p>11. Dachpfetten / Purlins / Pannes de toit</p>		<p>Holzschraube / Screw / Vis de fixation 5x120 (HS3)</p>
<p>12. Deckleisten / Corner cover strips / Profils de finitions des angles</p>		<p>Screw 3.5x35 (HS14)</p>

<p>13. Dachstützen / Roof supports / Supports d'extrémité de toit</p>		<p>Holzschraube / Screw / Vis de fixation 5x90 (HS1)</p>
<p>14. Dachbretter / Roof boards / Voliges de toit</p>		<p>Drahtstift / Nail / Pointes 2x 50 (DS1)</p>
<p>15. Dachpappe (nicht inklusive) - Roofing felt (not included) - Feutre bitumeux (non inclus)</p>		

<p>16. Giebelleisten / Gable mouldings / Planches de rives</p>	<p>The diagram illustrates the installation of gable mouldings (GL1 and GL2) on the roof of a structure. The roof is supported by rafters (HS6). The mouldings are attached to the rafters using screws (HS6). A ladder is shown on the left, and tools like a level, tape measure, and power drill are shown on the right.</p>	<p>Holzschraube / Screw / Vis de fixation 3.5x50 (HS6)</p>
<p>16. Giebelleisten / Gable mouldings / Planches de rives</p>	<p>The diagram illustrates the installation of gable mouldings (GL1) on the roof of a structure. The roof is supported by rafters (HS6). The mouldings are attached to the rafters using screws (HS6). Battens (BL) are also shown. A ladder is shown on the right, and tools like a level and power drill are shown on the left.</p>	<p>Holzschraube / Screw / Vis de fixation 4x40 (HS4)</p>
<p>17. Dachpappenleiste / Roofing felt fillet / Profils de finitions de toit</p>	<p>The diagram illustrates the installation of a roofing felt fillet (DPL1 and DPL2) on the roof of a structure. The roof is supported by rafters (HS6). The fillet is attached to the rafters using nails (NF). A ladder is shown on the right, and a power drill is shown on the left.</p>	<p>Drahtstift / Nail / Pointes 2x40 (NF)</p>